MeccoMark[®] Flash Lamp Marking System

Technical Specification



Rev 1

System Overview:

For high reliability and flexible operations, our Flash lamp series of marking systems are the most versatile lasers offered. Based on industrial proven technology, the flash lamp laser can work in all types of environments and applications. It's rugged design ensures long laser lifetime with minimal maintenance. Whether you are surface etching 2D data matrix and serial numbers or deep engraving Bumpy barcodes and logos, this laser can do the job.

Standard Features:

- 50, 85, 100 and 150 Watt models
- Flash Lamp Lifetime between 500 to 1,000 hrs
- Q-Switch for peak power
- Variable Beam Expander for spot control
- Water cooled, requires external chiller
- Windows based software interface
- Integrated Safety Shutter
- High Performance Scanhead
- 110mm square mark field
(Other field sizes available)
- One Year System Warranty

Optional Accessories:

- Visible Pointer for mark preview
- 175mm, 250mm and 305mm square mark fields
- Class I Safety Enclosure
- Rotary Indexer for cylindrical marking
- XY and Z Class 1 Automated Workstations
- Rotary Workstations

System Benefits:

- Industrial proven design
- High reliability and system up-time
- Highest laser power versus initial costs of any marking laser
- Field replaceable components for on-site repair

General Laser Safety:

The MeccoMark Flash Lamp Laser Marking system can be supplied in either Class IV or Class 1 configuration. The standard system (without enclosure) is a Class IV system. The laser operator is exposed to laser radiation at the work surface. This laser radiation can be harmful to the operator if laser light is scattered or reflected into the eye.

If the system is sold as a Class IV system, it is the responsibility of the integrator to properly safeguard the operator from laser radiation. The MeccoMark Flash Lamp Laser Marking System does comply with the Center of Device and Radiological Health and Safety Act of 1968.

The Class IV system features:

- Spring Loaded mechanical safety shutter
- Emergency Off (EMO) circuitry and pushbuttons
- Remote Interlock (RIC) circuitry for use with external equipment such as Class 1 Enclosures and/or safety guarding.

If the system is sold as a Class 1 system, the operator is properly protected from laser radiation. Mecco has submitted this design to the CDRH to be compliant with all safety regulations per 21 CFR 1040.10.

The Class 1 system features:

- Spring Loaded mechanical safety shutter
- Emergency Off (EMO) circuitry and pushbuttons
- Remote Interlock (RIC) circuitry
- Light-tight safety enclosure with interlocked doors and access panels.

Please consult the Flash Lamp Laser Operator Manual for full laser safety information.

Laser Specifications:

Parameter	Value	Notes
Laser type	Flash Lamp	Nd:YAG
Wavelength	1064 nm	
Output Power	50, 85, 100 & 150W Models	
Beam Quality	TEM00 and Multi-Mode	configurable
Operation Mode	Q-Switch	
Pulse Rep Rate	1 to 100 kHz	
Cooling	Water	External Chiller required

Performance Specifications:

Parameter	Value	Notes
Repeatability	+/- 1 part in 4,000	
Max Line Speed	3,000 mm/sec	Using 160 lens
Max Characters	250 character/sec	Using 160 lens, 1mm high characters on mirror

Computer Specifications:

Parameter	Value	Notes
Operating System	Windows 2000 or XP	
Processor	Pentium or better	
Processor Speed	500 MHz min.	
RAM	128 MB min.	
Hard Disk	4.3 GB min.	
Screen Display	1024 x 768 resolution min	

Environmental Specifications:

Parameter	Value	Notes
Electrical	220 10% VAC, 3-phase, 50/60 Hz, 20A	
Operating Temp.	15°C to 35°C	
Relative Humidity	20 to 90%	
Warm-up time	30 minute for full stability	Laser can be fired after 1 minute of warm up time.

Dimensions and Mounting Features: Laser Rail

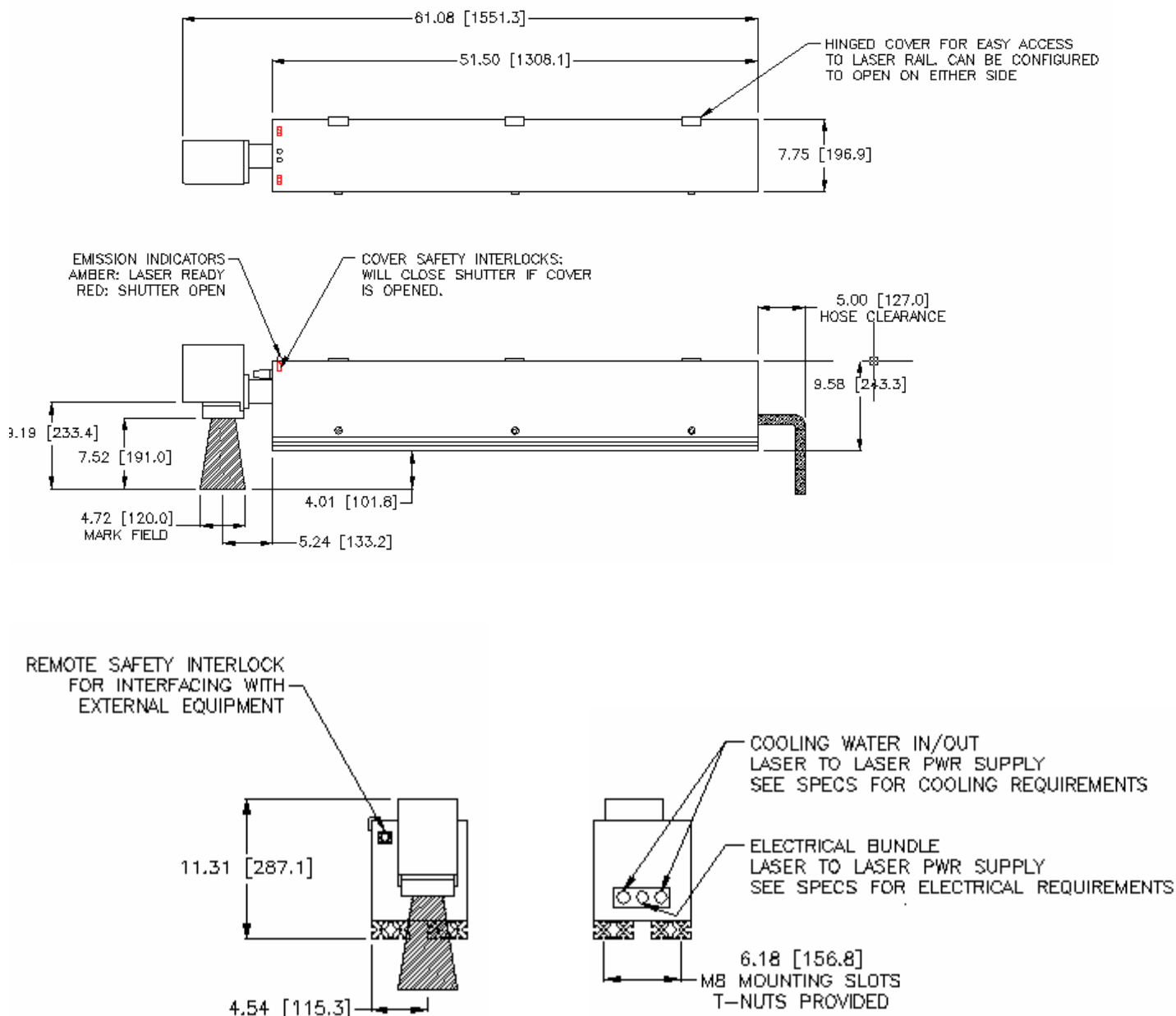

Dimensions and Mounting Features: Laser Power Supply

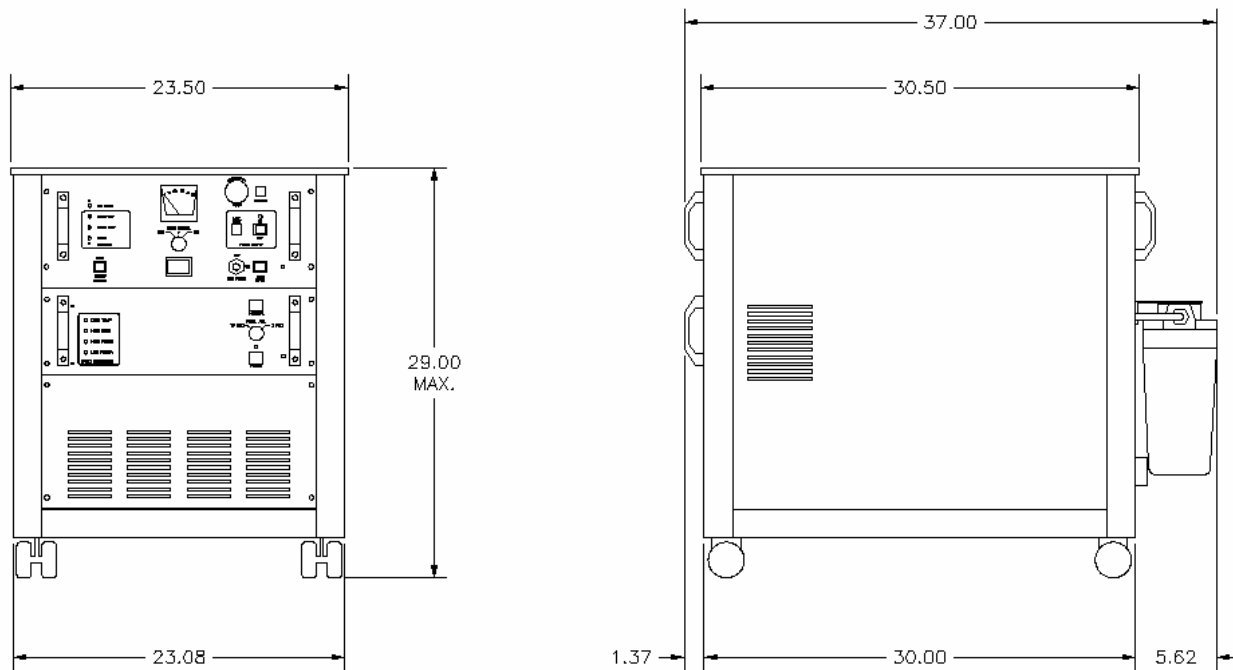

MeccoMark Laser Marking Software:

The power, ease and flexibility of MeccoMark's User Interface is the most advanced and professional package in industry. MeccoMark[®] laser scanning control software offers a robust and flexible solution to make your scanning control project a success. MeccoMark[®] control software is a fully featured, professional Windows based software package for laser marking, cutting, drilling, coding, perforating, and many other laser scanning applications. When combined with the Surf Board-USB board, a 2 or 3-axis scan head and a laser, the laser processing possibilities are endless.

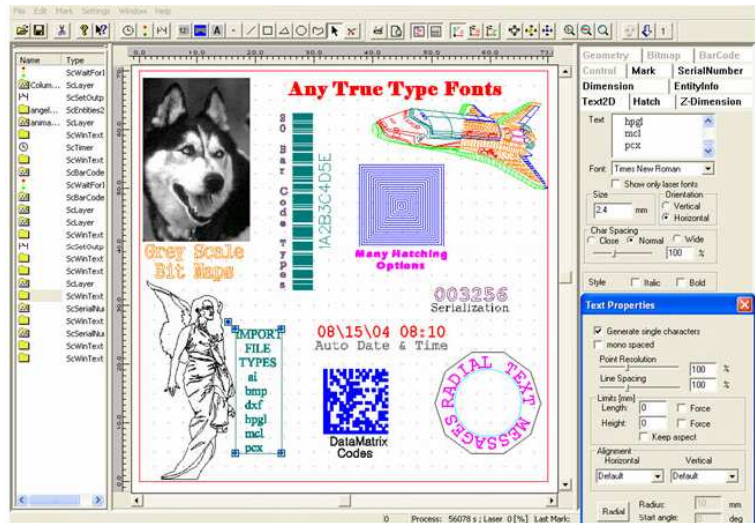

the

The software allows graphics job editing that enables you to assemble images, text, and barcodes and quickly arrange them into marking jobs. With a simple point and click, you can graphically edit marking objects, precisely control laser parameters, and build automation scripts within a single interface. You will be able to define and run jobs within a few minutes.

This high performance, laser scanning control solution is designed specifically to run on Windows 98, 2000 or XP. And with the built in Active-X Server, real time machine performance can be managed and monitored over an Ethernet network.

Features and Highlights

- USB 1.1 or 2.0 Interface
- For Win. 98/2000/XP
- Intuitive, Easy to Learn Graphical Interface
- Serialization & Text Merge
- Radial & Vertical Text
- Import Many Vector and Graphic File Types
- Scale, Rotate, and Mirror

- External Control Capable
- Mark Any Installed True Type Fonts and Barcodes
- Additional I/O Control for Material Handling
- Stepper/Servo Motion Control X/Y, Z, & Rotary
- Controls Any Laser Type
- Built In Lens Correction
- Remote Access & Control